

(No Model.)

4 Sheets—Sheet 1.

D. E. FELT.
ADDING MACHINE.

No. 405,024.

Patented June 11, 1889.

Fig. 1. k

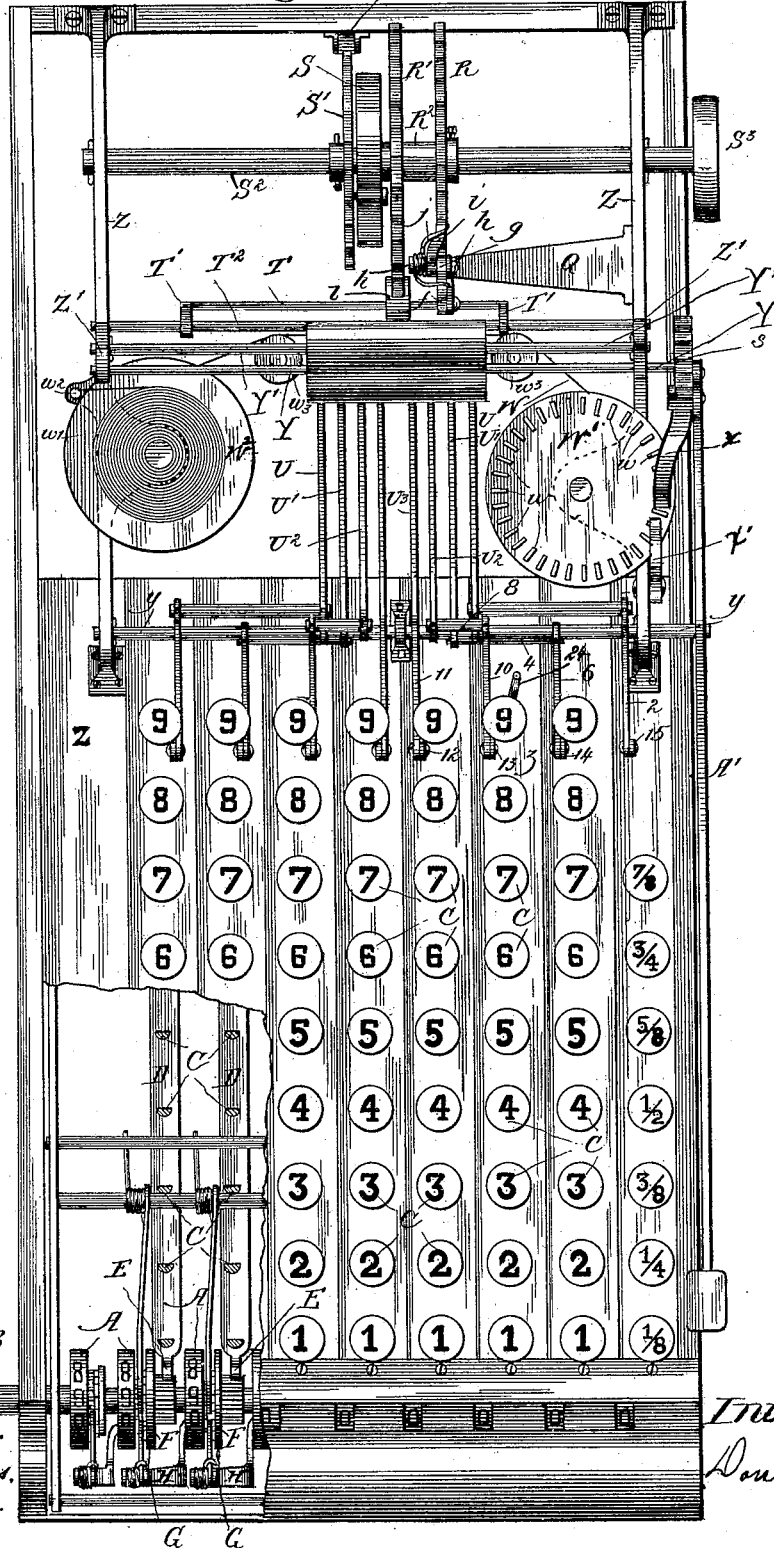

Witnesses:
Albert H. Adams.
Harry T. Jones.

Inventor:
Don E. Felt

D. E. FELT.
ADDING MACHINE.

No. 405,024.

Patented June 11, 1889.

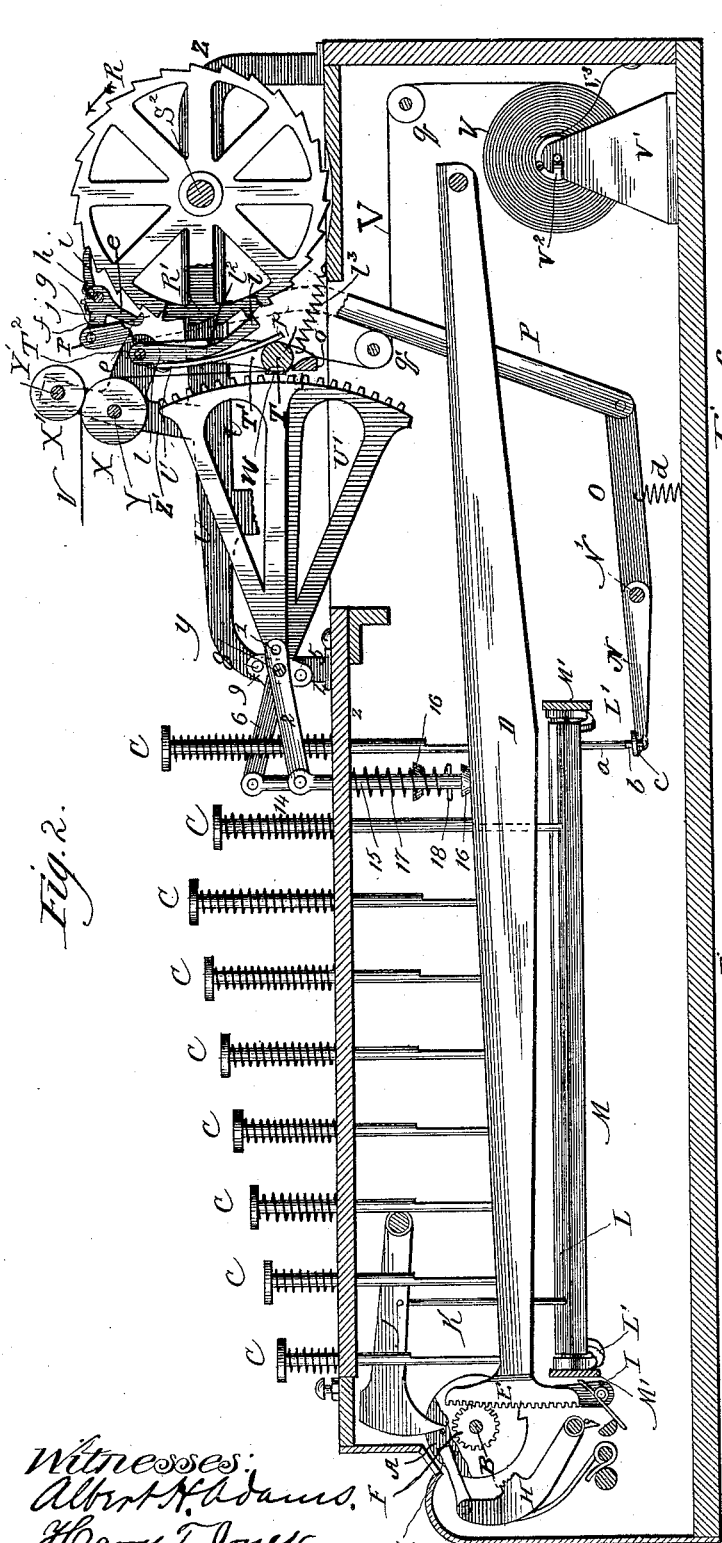

Fig. 2.

Witnesses:
Albert H. Adams.
Harry T. Jones.

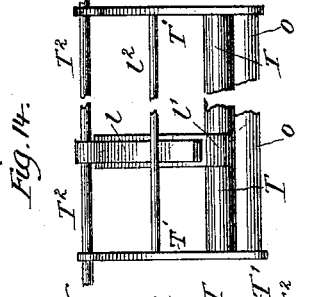

Fig. 4.

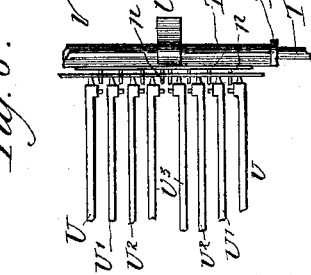

Fig. 5.

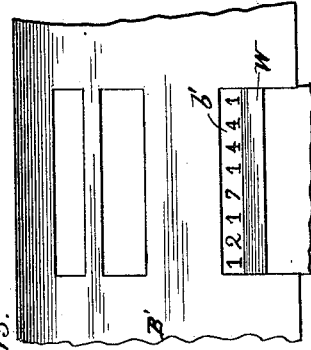

Fig. 6.

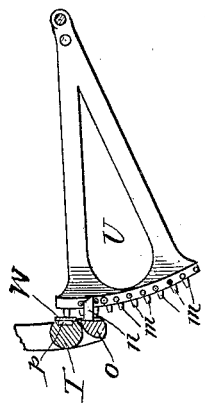

Fig. 13.

Inventor:
D. E. Felt.

(No Model.)

4 Sheets—Sheet 4.

D. E. FELT.
ADDING MACHINE.

No. 405,024.

Patented June 11, 1889.

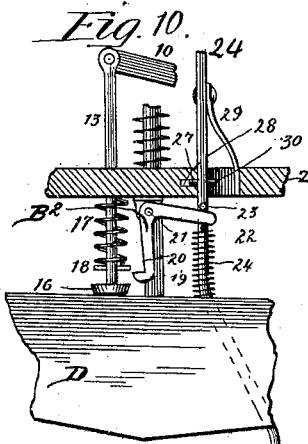
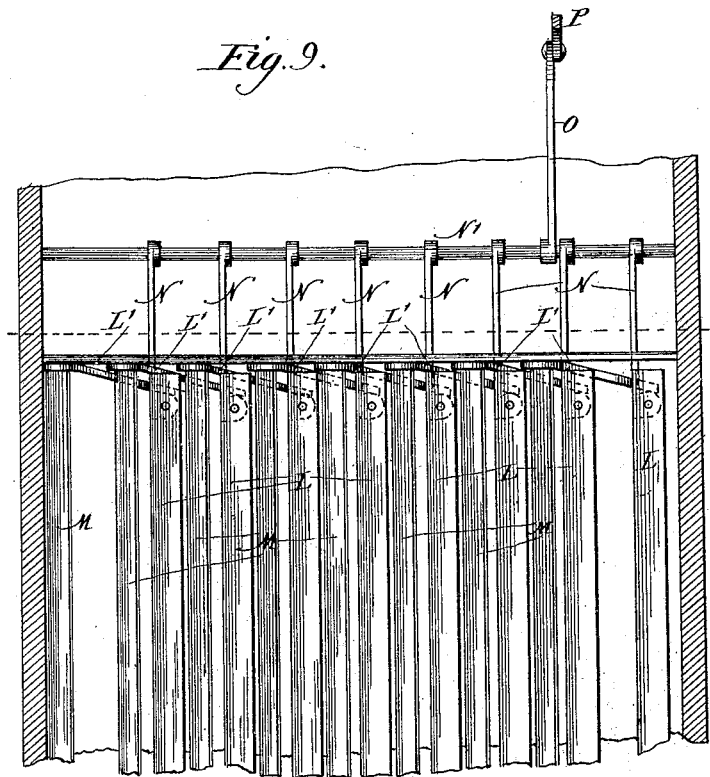
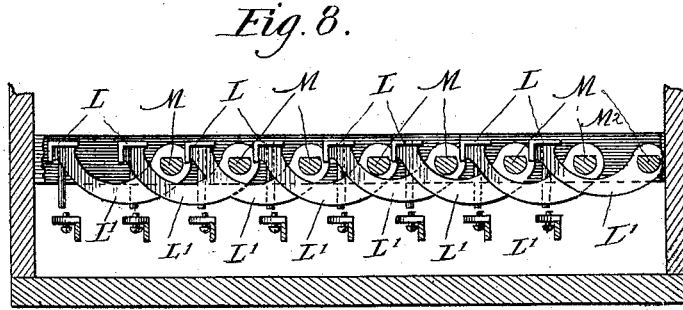
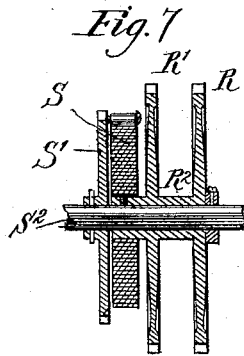

Witnesses:
 Albert H. Adams.
 Harry T. Jones.

Inventor:
 D. E. Felt.

UNITED STATES PATENT OFFICE.

DORR E. FELT, OF CHICAGO, ILLINOIS, ASSIGNOR, BY DIRECT AND MESNE ASSIGNMENTS, TO THE FELT & TARRANT MANUFACTURING COMPANY, OF SAME PLACE.

ADDING-MACHINE.

SPECIFICATION forming part of Letters Patent No. 405,024, dated June 11, 1889.

Application filed January 19, 1888. Serial No. 261,324. (No model.)

To all whom it may concern:

Be it known that I, DORR E. FELT, of Chicago, in the county of Cook and State of Illinois, and a citizen of the United States, have invented a new and useful Improvement in Adding-Machines, of which the following is a specification, reference being had to the accompanying drawings, in which—

Figure 1 is a top or plan view of a calculating-machine with the base or top plate broken out at one corner to show the numeral-wheels and their operating devices. Fig. 2 is a longitudinal section through the machine with some of the parts partly broken away. Fig. 3 is a longitudinal section through the machine. Fig. 4 is a detail in perspective showing the arrangement of one series or set of recording-heads. Fig. 5 is a detail, partly in section, showing a recording-head and devices coacting therewith. Fig. 6 is a detail, being a top or plan view showing the arrangement of the two series or sets of recording-heads. Fig. 7 is a detail in section of the ratchet-wheel, cam-wheel, and spring of the recording device. Fig. 8 is a detail, being a cross-section of the machine, showing the stop-levers and vibrating levers for operating the moving wheels for the recording devices. Fig. 9 is a top or plan view of the devices shown in Fig. 8. Fig. 10 is a detail, being a side elevation of the devices for throwing up the recording-head and for stopping the operation of such heads. Figs. 11 and 12 are a side elevation and an edge view, respectively, of the releasing-pawl for the power. Fig. 13 is a detail of the guard-plate for the recording-paper. Fig. 14 is a detail of the pressure-bar.

This invention is an improvement on the adding-machine for which Letters Patent were granted to me October 11, 1887, No. 371,496.

The machine is capable of performing many operations besides that of adding numbers, and may be called an "adding," "computing," and "recording" machine.

The leading objects of this invention are to provide in this class of machines for a perfect and accurate record of the added or com-

puted numbers, which record will be made at the same time that the numbers are added or computed and by the act of adding or computing, and to provide for throwing the recording mechanism out of operation without interfering with the operation of the adding or computing mechanism; and it consists in the several parts and combinations of parts hereinafter described and claimed as new.

In the drawings, A represents numeral-wheels, each standing for an order of numbers or fractions.

B is a shaft on which the numeral-wheels are mounted.

C are the operating-keys, a series being provided for each order of numbers or fractions, each key having a number or fraction upon it.

D are vibrating levers, one for each series of keys.

D' are springs for returning the levers D after they have been depressed.

E are toothed segments, one on the end of each lever D.

F are pinions on the shafts B, one meshing with each segment E.

G are disks—one for each pinion F—each integral with or secured to its pinion.

H are pivoted carrying-levers, one located adjacent to each numeral-wheel.

I are spring-actuated detents, which engage with the numeral-wheels, one for each wheel.

J are vibrating stops, one for each numeral-wheel.

K are rods, one connecting each stop J with its lever L. The parts above described are similar to the corresponding parts shown and described in my said patent, No. 371,496. Other parts and devices not shown herein, but shown and described in my said patent, are to be used to complete the machine.

L are stop-levers, one for each series of keys C, by which, when depressed, such levers will be thrown down and will cause the corresponding stop J to engage with its numeral-wheel.

M are rock-shafts, one for each stop-lever L, which shafts are supported in cross-bars

M' , which are supported in the casing of the machine. Each stop-lever L is connected with its rock-shaft by curved arms L' , one at each end, and a curved arm L^2 at the center, (see Figs. 2, 3, 8, and 9,) so that when struck by any one of its series of keys the lever will be rocked down, operating one of the stops J through a connecting-rod K , and each such lever will be returned by a spring on the stop or in some other suitable manner. Each lever L has a firm and steady support by the curved arms from the rock-shaft M , which will prevent any twisting or vibrating of the lever when struck, and this support extends the entire length of the lever, so that each key will engage the lever in the same plane, assuring its depression to the extent of the descent of the key. The arms L' are inclined somewhat to allow the arms to lie side by side. Thus the levers can be located within the case under their respective keys and each will be given a longer leverage and greater freedom of movement by reason of the length of the arms. As shown in Fig. 8, each stop-lever is angular, but might be straight. A pin a depends from the inner end of each lever L .

N is a series of levers, one for each lever L , each firmly mounted upon a rock-shaft N' , supported in the sides of the case. Each lever N has an ear c at its free end, in which is an adjustable screw b , which is in line with the pin a on that stop-lever L which is the companion of a lever N , so that the depression of the lever L will cause the pin a to engage with the screw b and force down the lever N to rock the shaft N' .

O is an arm or lever firmly secured to the rock-shaft N' , so as to be thrown up by the downward movement of any one of the levers N , and, as shown, this lever O will be returned to its normal position by the action of a coiled spring l , one end of which is secured to the lever O and the other to the base of the machine, thus returning the levers N to their normal position.

P is a bar, the lower end of which is pivotally connected to one end of the lever O . The upper end of this bar P extends above the casing of the machine.

Q (see Fig. 3) is a support secured at its lower end to the frame. At its upper end is a stud h , on which is mounted a pawl e , which pawl has an arm f attached to the upper end of the bar P by a pin g , so that by the movement of the bar P the arm f will turn the pawl e on its pivot h to throw it into or out of engagement with the teeth of the wheel R . On the pivot h is a pawl i , controlled by a pin i' and by a spring j , wound around the pivot h , which spring has one arm which engages with the pawl i and another arm which engages with the arm f . The pawl i also engages the teeth of the wheel R , as does the pawl e ; but the two pawls operate independently to a certain extent.

R is an escapement-wheel with the teeth of

which the pawls e i engage. The location and movement of these pawls in relation to each other and the wheel-teeth are such that when the arm P is down, as in Fig. 3, the pawl e will be in clutch with a tooth of the wheel and the pawl i will be above a tooth, and when the bar P is raised, as shown in Fig. 2, the pawl e will be released and the pawl i be forced into engagement with the next tooth of the wheel R , which moves in the direction indicated by arrows in Figs. 2 and 3. The pin h is stationary, so that the movement of the bar P up will move the pawl e out of clutch and the movement of the bar P down will throw the pawl e into clutch, and at the same time the pawl i will be lifted out of clutch by the action of the pin i' ; and when the pawl e is thrown out of clutch the pawl i will be thrown into clutch by the action of the spring j , the result being that the escapement-wheel R can only advance one tooth at a time.

R' is a wheel, the periphery of which is provided with a series of teeth which serve the purpose of cams and act on a rubber l . This wheel is connected with the wheel R by a hub R^2 , Fig. 1, and thus both of the wheels R R' move one tooth at a time.

Instead of providing the wheel R' with a series of teeth, it might be made with only one tooth and be provided with multiplying-gears to produce the same effect as the construction shown.

S is a spring similar to a clock-spring, one end of which is secured to the hub R^2 , (see Fig. 7,) the other to a pin on a ratchet-disk S' , with the teeth of which a pawl k engages to hold the spring from unwinding except when the wheel R is released from its pawls. This disk S' is secured to a shaft S^2 , on which the hub R^2 , which carries the wheels R R' , rotates. The shaft S^2 is supported in the frame and has at one end a button S^3 , by which it can be turned to wind up the spring S .

T is a pressure-bar supported at its ends by arms T' , suspended from a rod T^2 , so that the pressure-bar can swing. The rubber l is suspended from this rod T^2 in such a manner that its free end will engage the cam-acting teeth of the wheel R' , so as to impart an oscillating movement to the pressure-bar T and its supporting-arms T' at proper intervals.

V is a spring, one end of which is secured to the rubber l and the other end bears against the pressure-bar T and renders the action of the bar less rigid than it otherwise would be, and also communicates the power from the rubber l to the pressure-bar T .

U U' U^2 U^3 are recording type-heads pivoted on the shaft y , which is secured in supports on the casing. There are two sets of type-heads of four each to correspond with the several series of keys C , and each key of each series of keys will, when operated, bring into action the particular recording-head belonging to that series of keys. The head U is for the fractions, the head U' for the units, the head U^2 for the tens, and the head U^3 for the

hundreds. Each recording-head has on its face figures corresponding to the figures of the keys, seven being provided for the fractions-head and nine for each of the other heads.

5 Fig. 4 shows the construction and arrangement of one set of recording-heads, and the other set is similar in construction and arrangement, one set being right-handed and the other left-handed.

10 The head U has extending out from its side a rod 1, which is secured to an arm 2, and on a shaft y the head U and its actuating-arm 2 are pivoted. The head U' has an ear 3 at its pivoted end, in which a rod 4 is secured, which
15 rod is also secured to an ear 5 of an operating-arm 6. The head U^2 has at its pivoted end an ear 7, in which is secured a rod 8, which rod is secured to an ear 9 on an arm 10. The head U^3 extends back of the pivot-shaft y ,
20 forming an arm 11, and this arm and also the arms 6 and 10 turn on the shaft y as a pivot. A rod 12 is pivoted to the arm 11 and extends down therefrom and rests upon the lever D of that series of keys C with which the head
25 U^3 operates, and this rod, as shown, has at its lower end a head 16, above which is a pin 18, against which rests the end of a coiled spring 17, which is wound or coiled around the rod 12 and abuts at its upper end against the under
30 side of the top plate z of the casing. A similar rod 13 is provided for the arm 10 of the head U^2 , which rod rests on the lever D for that series of keys which coacts with the head U^2 . The arms 6 and 2 for the respective
35 heads U' and U are provided with similar rods 14 and 15, with a cross-pin 18 and spring 17 for each, which rods rest, respectively, on the levers which act with the recording-heads U' and U . The other set of type-heads is similar
40 to that shown in Fig. 4, and is adjacent to its companion set, as shown in Fig. 1, which figure also shows the relation and connection between each recording-head and its series of keys.

45 Each rod 12 13 14 15 has a catch 19 on one arm 20 of a bell-crank lever B^3 , which catch is located in line with the pin 18, and the several bell-crank levers are rigidly secured to a rock-shaft 21, mounted in ears, so that the
50 movement of one bell-crank lever will move all of them and throw all the catches 19 beneath all the pins 18 of the rods of both sets of the recording-heads and prevent the descent of the rods and the consequent elevation
55 of the recording-heads.

The arm 22 of one bell-crank lever lies in engagement with a pin 23 on a rod 24, which extends above the case and down into the machine, and its lower end has a slot 25, which engages a pin 26 on lever N , which slot permits
60 the movement of the lever N when the rod 24 is in the position shown in Fig. 3, a pin 27 on said rod there entering a recess 28 in the top z of the casing, locking the rod stationary. This rod
65 passes through a slot 30 on the top of the case and is held locked by a spring 29, which spring and the slot permit the rod to be moved by

hand to disengage the pin 27, and then the rod can be pushed down so that the pin will engage the under side of the top z , and with
70 such movement the pin 23 will force down the arm 22 of the bell-crank lever engaged therewith and throw all the bell-crank levers forward, and the catches 19 will engage the
75 pins 18. At the same time the engagement of the rod 24 with the pin 26 carries down the levers N , so that no contact can be had between the several pins a and the screws b , thus preventing the operation of the lever N by its stop-lever L , also stopping the operation of the bar P , and consequently that of
80 the recording devices.

Each recording-head has on one of its side faces a series of pins m , Fig. 5, which are set at a proper distance apart to permit the entrance
85 between them of the stops n , which are carried by a cross-piece o , secured by the arms T' below the pressure-bar T . These stops and pins perform the office of centering the numeral which is to be imprinted on the paper and holds the head steady during the im-
90 printing operation, and, as shown, each figure of each head is made to center with a cushion p on the pressure-bar, which cushion allows the pressure-bar to yield a little, so as not to
95 hurt the face of the type.

V is the strip of paper on which the record is to be made, which strip is unwound from a roll of paper mounted on a shaft supported in standards V' , and on the shaft is a friction-
100 disk V^2 , against which the end of the spring V^3 bears to prevent too rapid unwinding of paper. The strip passes over the roller q and under a roller q' , thence over the cross-piece
105 o and up in front of the pressure-bar P and between feed-rollers X X' on shafts Y Y' . The shaft Y' is mounted on sliding bars r , each located in a slot r' in which is a coiled spring r^2 , by which the roller X' is pressed
110 onto the roller X .

Z Z' are bars secured to the top of the casing, and furnish a support for the shafts S^2 and y . To one of these bars the arm or support Q is secured. The bars Z have upward
115 extensions Z' , which furnish a support for the shafts Y Y' and rod T^2 . The shaft Y projects at one end beyond its support, and to this end is secured a ratchet-wheel s .

W is an inking-ribbon running from the spool W^2 to a spool W' , and guided in front
120 of the pressure-bar by rollers w^3 . The spool W^2 has secured to its shaft a coiled spring w' , the other end of which spring is secured to a spring w^3 , and the ribbon is held tight by the action of the spring w' .
125

A' , Fig. 1, is a lever pivotally mounted on the shaft y , and having at its rear end an extension u , Fig. 3, to which a pawl x is secured
130 by a pin v' , which pawl engages with the ratchet-teeth w on the spool W' . The rear end u of the lever A' has a pawl t pivotally secured to it by a pin t^2 , the acting end of which pawl engages a tooth of the ratchet-wheel s , with which the pawl is held in en-

gagement by a spring t' . The lever A' is returned to its normal position, after being operated, by a spring a' . When the front end of this lever A' is pressed down, its rear end will rise, raising the pawl t to engage with a ratchet-tooth on the wheel s , and will retract the pawl x to engage a ratchet-tooth on the spool W' , and on the release of this lever the spring a' will return the lever, causing the pawl t to advance the ratchet-wheel s and rotate the roller X , carrying the paper V forward, and at the same time the wheel W' will be advanced by the pawl x , winding the ribbon W thereon. The levers M and O , bar P , arm f , pawls e and i , and ratchet-wheel R constitute an escapement mechanism for releasing the wheel R' by the action of one of the levers L , for the purpose of allowing the power, which in this case is in the spring S , to actuate the wheel R' and operate the pressure-bar T , and make an impression of the struck figure on the paper.

The construction of the machine is such that the descent of a lever D , by the striking of a key, will raise the corresponding type-head, so that the figure on the head corresponding to the key struck will be opposite to the pressure-bar, and the descent of the lever L at the end of the stroke of the key will actuate the escapement to release the cam-wheel R' and cause an impression of the figure presented by the type-head to be taken by the action of the pressure-bar.

B' is a guard or shield, in which is an opening b' , located in front of the paper V and in line with the stopping-point of the row of recorded numerals when advanced, so that only the row last advanced can be observed, the other rows being covered by the shield, so that the operator will not be confused when looking at the record.

Instead of locating the head 16 on the ends of the rods 12, 13, 14, and 15, the heads can be secured to the levers D in line with the rods, and may be cup-shaped to insure the correct centering of the rods.

The bars T' of the pressure-bar and the rod or bar l^2 together form a frame, and the rod l^2 holds the rubber l and the spring l' in proper relation to the pressure-bar, and without this rod l^2 the pressure-bar would be constantly forced against the type-heads.

The operation of the adding and computing devices is similar to that set forth in my said patent.

The operation of the recording devices is as follows: When any key of any one series of keys C is pushed down, it first causes the lever D to move downward, operating one or more numeral-wheels, as in my former patent. The descent of the key also causes the lower end of the key to bear on a lever L , forcing such lever down and causing a stop J to engage with and arrest the numeral-wheel, also bringing the pin a on the lever L into contact with the screw b on the lever N , forcing such lever down, which raises the lever O and

lifts the bar P , releasing the pawl e and allowing the wheels $R R'$ to be rotated a distance of one tooth by the action of the spring S , causing a tooth of the wheel R' to push out the rubber l and carry forward the pressure-bar T . Such descent of the lever D allows the rod of the recording-head, with which the lever coacts, to descend by the action of a coiled spring, which throws up the recording-head the distance required to bring the figure on the head corresponding to the struck key in line with the pressure-bar, so that the forward movement of the bar will produce through the inked ribbon an impression of the figure on the sheet of paper. Each succeeding figure of the number added or computed will be recorded in like manner. The several figures of each item or number can thus be recorded on the strip of paper, and when the record of each item is complete the operator, by pressing down on the lever A' , can bring the pawls t and x into operation to advance the paper and ribbon, and another item or number can be recorded in like manner.

The several recording-heads have the numerals arranged thereon corresponding to the numerals on the striking-keys, and the distance that each head moves is controlled by the distance the key moves the lever D , so that the descent of each key will move the head sufficiently to bring the numeral on the head corresponding to that on the struck key in line with the pressure-bar.

The depression of any one of the fraction-keys will operate the head U through the rod 15, arm 2, and one of the springs 17. The depression of any one of the keys of the unit series will operate the head U' through the rod 14, arm 6, rod 4, and a spring 17. The depression of any one of the keys of the tens series will operate the tens-recording head U^2 through the rod 13, arm 10, rod 8, and a spring 17; and the depression of any one of the keys of the hundreds series will operate the hundred-head U^3 by the rod 12, arm 11, and a spring 17. In like manner the depression of any one of the keys of the remaining series of the adding-machine will operate the coacting recording-head through the connecting devices.

With the release of each key C all the operating parts will be returned to their normal position by the action of the springs. Each recording-head is positively stopped by the action of pins m and stop n , which stoppage occurs when the figure to be recorded is in line with the pressure-bar.

The pawls $e i$ are double-acting in the sense that when one is released the other becomes engaged; but the release of the pawl e permits the wheel R to advance a much greater distance than does the release of the pawl i , and this difference produces a saving of the power, nearly all of the power of the spring S being utilized in making record on the paper, very little being lost when the parts are returning to their normal positions.

The spring S can be wound up by turning the shaft S² through the disk S', and when the ribbon is unwound from its spool W² the spring of the spool will wind the ribbon back thereon when the spool W' is released from its pawl *x*. The ribbon-spool W' is held against the action of the spring of the spool W² by a pawl *x'*, arranged to engage the stop *w* and prevent the back rotation of the spool, the acting end of the pawl *x'* being of such shape that it allows the spool W' to be advanced by the pawl *x*.

When it is desired to have the recording devices thrown out of use, the rod 24 is to be operated to throw the bell-crank lever into engagement with the several rods of the recording-head and lock down the levers N, as before described.

What I claim as new, and desire to secure by Letters Patent, is as follows:

1. The combination, with the series of keys of an adding-machine, of a series of levers L, operated by said keys, a series of numeral-wheels A, type-heads, as U U' U² U³, a series of levers N, a rock-shaft N', common to all of said levers, stops J, wheels R and R', and an escapement mechanism between each of the levers L and the wheel R, substantially as and for the purposes specified.

2. The combination, with the series of keys of an adding-machine, a series of levers N, a common rock-shaft N', upon which said levers are mounted, and connections between said keys and levers, of an arm or lever O, carried by the rock-shaft, a bar P, connected with such arm or lever and carrying a compound pawl *e i*, a coacting escapement-wheel R, a pressure-bar T, and a wheel R', having teeth for advancing the pressure-bar, substantially as described.

3. The combination, with the series of keys of an adding-machine, of a series of stop-levers L, connections between said keys and levers, a series of levers N, operated from the stop-levers, a rock-shaft N', common to all of the levers N, an arm O, carried by the rock-shaft, a bar P, connected with said arm and carrying a double-acting pawl, an escapement-wheel R, with which the pawl coacts, a wheel R', connected with the wheel R and having a series of teeth, a moving power for both the wheels R and R', a pawl coacting with the teeth of the wheel R', and a swinging pressure-bar T, substantially as described.

4. The combination, with the series of keys of an adding-machine, an escapement mechanism, and the bar P, carrying a double-acting pawl, of the toothed wheel R', means for actuating the escapement mechanism and the toothed wheel R', and the pressure-bar T, acted on by the toothed wheel, whereby said pressure-bar is forced against the paper to make an impression thereon with the descent of each key of the adding-machine, substantially as described.

5. The combination of the series of keys of an adding-machine, the levers L and N, connections between said levers, substantially as described, a common rock-shaft N', on which all the levers N are mounted, an arm O, carried by said rock-shaft, a bar P, pivotally connected with said arm and carrying a double-acting pawl, the escapement-wheel R, and the connected wheel R', whereby said wheel R' is advanced step by step with the striking of each key, substantially as described.

6. The combination, with the series of keys of an adding-machine, the bar P, carrying a compound pawl *e i*, and connections, substantially as described, between said bar and keys, of an escapement-wheel R, controlled by said pawl, the toothed wheel R', means for moving both wheels R R', the rubber *l*, and the pressure-bar T, substantially as described.

7. The combination, with several series of keys C of an adding-machine, a series of vibrating levers D, operated by said keys, and a series of numeral-wheels, of a recording-head for each series of keys, and connections between each vibrating lever and recording-head for operating said recording-head by the movement of said lever, substantially as described.

8. The combination of several series of keys C, a series of vibrating levers D, actuated by said keys, a series of numeral-wheels, a series of type-heads, and connections between the vibrating levers and the type-heads, substantially as described.

9. The combination of the keys C, the numeral-wheels A, and the levers D with rods, as 15, springs, as 17, arms, as 2, and a series of type-heads, substantially as described.

10. The combination of the numeral-wheels A, the series of keys C, stops J, levers L, levers N, rock-shaft N', having arm O, bar P, connected to said arm, and an escapement mechanism actuated by said bar, substantially as described.

11. The combination of a series of levers L and series of arms or levers N, a rock-shaft N', common to the levers N, arm O, a bar P, pawls *e* and *i*, wheel R, toothed wheel R', rubber *l*, and pressure-bar T with the keys C, levers D, and a series of recording-heads operated from the levers, substantially as specified.

12. The combination, with the rock-shaft N', levers N, mounted thereon, and the levers L, and rock-shaft M, of the inclined connecting-arms L' between the levers L and rock-shaft M, for giving said levers uniform support, substantially as described.

DORR E. FELT.

Witnesses:

ALBERT H. ADAMS,
HARRY T. JONES.