

H. GOLDMAN.  
CALCULATING MACHINE.

(Application filed Sept. 9, 1897.)

(No Model.)

2 Sheets—Sheet 1.

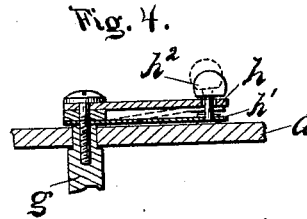
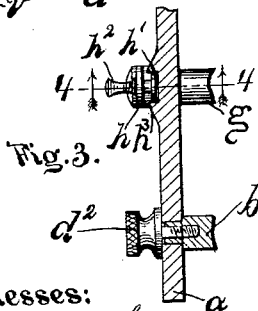
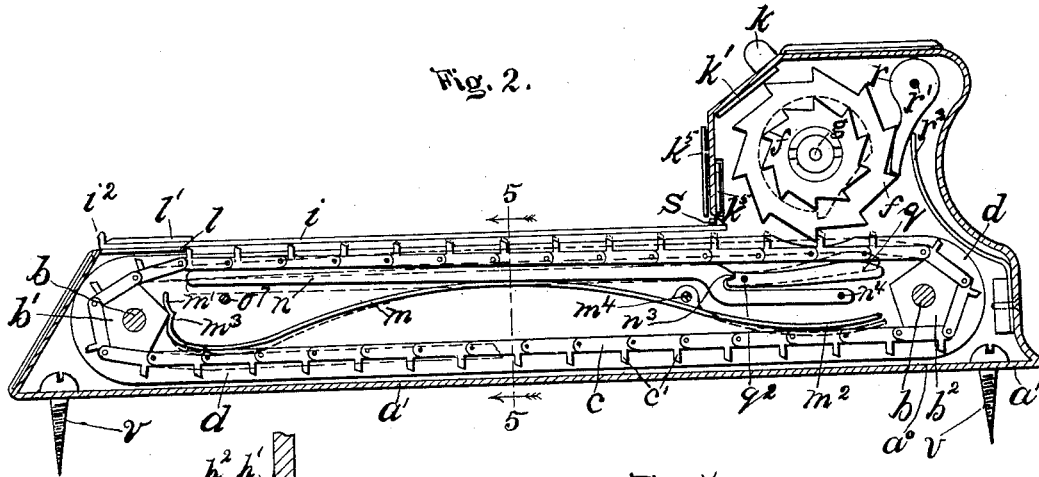
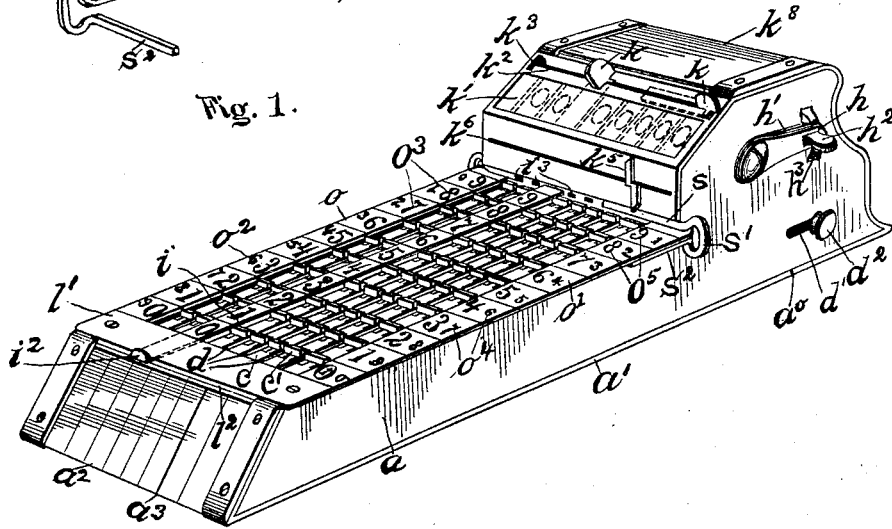
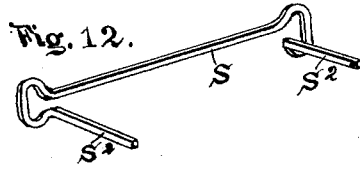

Witnesses:

*E. D. Jaeger.*  
*J. Buehler.*

Inventor.

*Henry Goldman*

By *Wm. Zimmerman* Atty.

No. 624,788.

Patented May 9, 1899.

H. GOLDMAN.  
CALCULATING MACHINE.

(Application filed Sept. 9, 1897.)

(No Model.)

2 Sheets—Sheet 2.

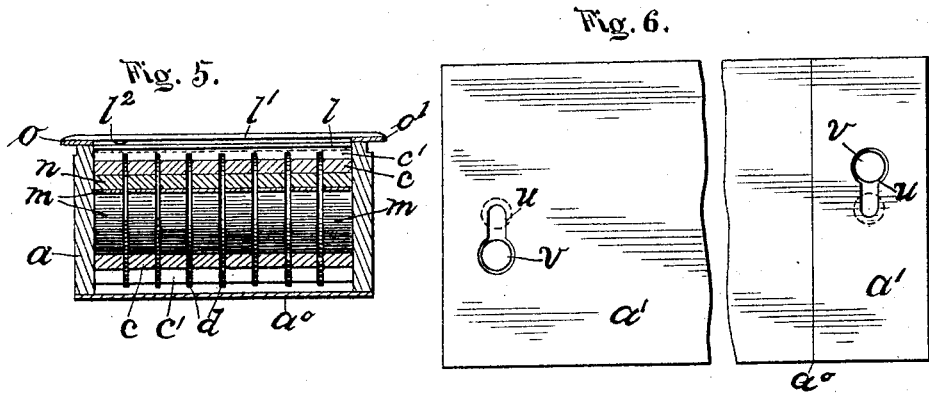

# UNITED STATES PATENT OFFICE.

HENRY GOLDMAN, OF CHICAGO, ILLINOIS, ASSIGNOR TO THE INTERNATIONAL ARITHMACHINE COMPANY, OF SAME PLACE.

## CALCULATING-MACHINE.

SPECIFICATION forming part of Letters Patent No. 624,788, dated May 9, 1899.

Application filed September 9, 1897. Serial No. 651,063. (No model.)

*To all whom it may concern:*

Be it known that I, HENRY GOLDMAN, a citizen of the United States, residing at Chicago, in the county of Cook and State of Illinois, have

5 invented certain new and useful improvements in Calculating-Machines, which are fully set forth in the following specification, reference being had to the accompanying drawings, forming a part hereof, in which—  
10 Figure 1 shows my said new calculating-machine in perspective. Fig. 2 shows the same in sectional side elevation, the cutting-plane passing just outside of the chain, spring, and drums. Fig. 3 shows a fragment of the  
15 side of the case in section, taken under the handle and through the drum-shaft, the latter being also shown in section. Fig. 4 shows a longitudinal section of the handle, its shaft, and a fragment of the case. Fig. 5 shows a  
20 transverse section of Fig. 1, taken on the plane 5 5 of Fig. 2 and seen in the direction of the arrows. Fig. 6 shows two end fragments of the bottom of the outer casing supplied with fastening mechanism. Fig. 7 shows  
25 the levers  $n$  and  $q$  detached from each other in perspective, which are shown in side view in Fig. 2 connected. Fig. 8 shows a spring of special form, operating the levers shown in Fig. 7, and other parts. Fig. 9 shows a  
30 septum of the series which separate each chain and its therewith-connected operating mechanism from the chains and mechanism to each side of it. Fig. 10 shows a modified construction of both chain and drum. Fig. 11 shows  
35 a chain-cover in perspective. Fig. 12 shows in perspective an adjustable pencil-stop.

Like letters of reference denote like parts.

The object of my invention is to improve the details of construction of my earlier-invented calculating-machine, for which applica-  
40 tion for Letters Patent was filed January 25, 1897, as serial number 620,630, and I construct and operate said parts substantially as follows, namely:

45 The case  $a$  is made as formerly; but its bottom is divided into two parts on the line  $a^0$ , making two parts  $a' a'$ . The interior of the case  $a$  is divided into separate compartments by longitudinal septums  $d$  to form as many  
50 such compartments as there are chains  $c$ . Said septums rise above the said chains at

the upper half of the chains and also pass below them at the lower edge of the septum. To insure perfect action of the chain-spurs  $c'$  on the registering-drums  $f$  and the checking of  
55 the motion of the chains at the right instant, I provide a long lever  $n$  with a transversely-connected parallel member  $n'$ , so as to form a recessed notch  $n^2$  in said transverse connection and a spur  $n^3$  above it, and fulcrum it at  
60 the outer end of  $n'$  on a pin  $n^4$ , and into said notch  $n^2$  is passed the point  $q'$  of a lever  $q$ , fulcrumed on a pin  $q^2$ . Said levers are placed within each chain  $c$  and held by pins through  
65 holes  $n^5$  in the septum, and holes which hold the pin  $n^4$  of the lever  $n'$ , and by pins through holes  $q^5$  of the septums and holes  $q^2$  of the lever  $q$ . The said levers are so placed that their respective outer or free ends may serve  
70 several definite purposes. As here shown, the end  $n^0$  of the lever  $n$  serves to raise the chain upward, so that its spurs  $c'$  may be caught by the front edge of the plate  $l$ , and  
75 thereby have their motion arrested, which otherwise might pass beyond the designed position.

In Fig. 2 the chain-spur is shown held at the edge of the plate  $l$ . The broken outlines show the position of the chain and lever when depressed by a stylus or pencil in the hand,  
80 by means of which the chains are actuated. The lever  $n$  being in close contact with the under edge of the upper part of the chain for its entire length will be depressed by the stylus when placed at any point along the  
85 exposed chain-surface, and thus release the chain-spur  $c'$  from the edge of the plate  $l$ . At the same instant that the chain is released by the depressing-stylus it makes sure contact with the registering-drums  $f$  by means  
90 of the lever  $q$ , then raised into the position indicated by the broken outlines, and thus causes the spurs  $c'$  to make such full contact with the teeth of the registering wheels or  
95 drums  $f$  as to make their operation positive and unfailling, at the same time allowing that looseness of chain and consequent freedom from friction so necessary for the desirable and perfect working of such a machine.

The spring  $m$  makes contact with the lever  
100  $n$  at about the point where the transverse cutting-plane 5 5 is indicated and lifts said

lever against the chain and raises it to the position indicated in Fig. 2. Said spring is also in contact with the lower parallel member of the chain, and it assumes the position indicated by the broken outlines near the drum  $b'$  and depresses the chain into the position indicated by the broken outline, thus taking up the slack due to the depression of the upper parallel member of the chain. Said end of the spring is also turned into an end  $m'$ , provided with a notch  $m^3$  to catch the edges of the pentagonal drum or drums, so as to form an additional check against any acquired momentum of the connected moving parts and to bring each part to rest at its proper place. Said notch is so formed as to allow the edge of the drum to slip from it without undue resistance. At the opposite end of said spring is a free end  $m^2$ , which serves a like purpose of taking up any slack of the chain which forms when the chain drops from full contact with the drums  $f$ . One of the drum-shafts  $b$  carries the drums  $b'$  and the other shaft the drums  $b^2$ . The latter shaft is made adjustable by means of a slot  $d'$  in the sides of the case  $a$  and septums  $d$ . The shaft ends are secured by milled and shouldered set-screws  $d^2$  in the ends of the shaft.

The shaft  $g$  is turned and held by means of a combined arm and spring  $h h'$ , fixedly held by the shaft  $g$ . The arm  $h$  is rigid, while the arm  $h'$  under it and parallel thereto yields toward the arm  $h'$  as a spring, which normally presses upon the side  $a$ , and its outer end is held between opposed stops  $h^3$ , secured to the side  $a$ . A handle  $h^2$  passes freely through a hole in the arm  $h$  and is secured in the arm  $h'$ . By lifting outwardly on the handle  $h^2$  the arm  $h'$  is released from the stops  $h^3$ , after which the shaft  $g$  may be turned by said handle for the purpose of bringing all the numeral-wheels  $f$  to the zero or starting point, an operation always necessary for each new computation. A shaft  $o^7$ , through holes  $m^6$ , checks the downward motion of the end  $n^0$  of the lever  $n$ .

Near each end of the bottom of the case are cut slots  $u$ , whereof one end is enlarged into a circular opening to pass heads of screws  $v$ , secured in a board or other convenient device for holding said screws, the heads of which allow the bottom  $a'$  thereunder. After the screw-heads have passed through said slots the case ends are turned so that the screw-heads occupy the position indicated by the broken circles shown in Fig. 6. By means of the said construction the machine is quickly and securely fastened to a desk, table, wall, or board, where it will be held either for work or from accidental knocking about and injury.

The rotatable shutters  $k$ , which shut out numbers from the registering-dial  $k'$ , the slot  $k^2$  and slot ends  $k^3$ , decimal-point  $k^5$  and its slot  $k^6$  and upper tablet  $k^8$ , tablet  $a^2$ , with its dividing-line  $a^3$ , toothed registering-drums  $f$  and their shaft  $g$ , pawl  $r$ , pawl-shaft  $r'$ , and pawl-spring  $r^3$  are constructed and operated

substantially as shown in said former application. Flanges  $o o'$  are secured to the top edges of the sides of the case, and upon them is a double row of numerals, whereof each number of each transverse pair of numbers is the arithmetical complement of the other to "9" in the rows  $o^2 o^3$ , and similarly in the rows of numerals  $o^4 o^5$  each number of each transverse pair of numbers is the arithmetical complement of the other to "10." Each of the rows of larger numerals begins with a "0" at the edge of the stop-plate  $l$ . Therefore to make the first two numbers of the rows  $o^4 o^5$  complete the numeral "1" of the number "10" is written within the larger "0." The tablets  $o o'$  are connected by a transverse plate  $l'$ , overlapping their lower ends, and at the same time said plate forms the top side of a slot  $l^2$ , extending between the inner edges of said tablets. Through the slot  $l^2$  is passed a strip  $i$ , forming what may be called a "chain cover or guard," its function being to prevent the use of the chains  $c$  or a line of keys of keyed machines under it. Said stop, as here shown, has an upturned handle  $i^2$  and a spur  $i$  to enter holes  $i'$  in the lower edge of the wall, having the slots  $k^6$  to hold and adjust the guard to place. From one to several such stops may be used simultaneously on a machine, and thereby the machine becomes subdivided into two or more parts which will be adapted to give results independent of the other parts and whereof the final result of such several parts are independent of any other results. Said results may, however, subsequently be summed into a final unitary result. Numerals may also be put on said stops corresponding with the larger numerals of the side tablets, whose function is the same as that of the tablet-numerals. The chains or keys so stopped out do not of course prevent or change the proper action of the registering-wheels; but as the next registering-wheel is shut out, or, at least, to be so regarded, no confusion or injury can result until the next registering-wheel beyond the neutralized one is affected regularly in the series, and as that is a figure higher than required for all practical purposes under such subdivision of chains a very useful additional function of the machine is thus attained, because the sets of chains on each side of such stop are entirely independent and will not affect the practical result of one another, wherefore to such extent, as above stated, the said several parts or subdivisions become practically independent machines. It may also be observed that two or more such stops may be placed side by side, whereby the limit of advantage attained by such stops is made proportionally greater. Upon said tablets slides a transversely-placed adjustable bar  $s$ , forming a stop to the upward stroke of the stylus. Loops  $s'$  form its outer ends, and on said loops are opposed parallel bars  $s^2$ , which slide under said tablets and against the sides of the case  $a$ . Said lever

$n$  extends the entire length of that part of the chain or chains which can be depressed by the stylus, and thereby is formed a guide or track upon which that part of the chain slides without sagging, and thus relieves all the other parts of the machine directly connected with the chain from a great deal of injurious strain and wear which would take place except for said useful function of said lever.

All the directly essential functions of the lever  $n$  and nearly all the immediate results derived through its action and connection take place on the same chain side or part of the chain  $c$  which lies above the axial plane of the chain-drums.

In operating the machine the stylus is placed on the notationally highest chain and opposite the larger tablet-numbers corresponding with the given numeral and depressed as far as the lever  $n$  will go or allow, and then the stylus is moved with the chain until stopped at the edge of the plate  $l'$ . Then the next notationally lower number is taken and the stylus placed opposite the tablet number or numbers corresponding to it, and the chain moved as before, and so on. Addition is performed in this way, the result being direct and registered accordingly. In subtraction the minuend is registered according to the larger numerals of the tablet and the subtrahend according to the smaller numerals of the left-hand tablet or tablet  $o$ , excepting the units figure, which must be registered according to the smaller numerals of the right-hand tablet, the said arrangement of tablet-numerals and corresponding mechanical operation according to said numerals thus performed avoiding the mental consideration of numerical complements to nine or ten. In multiplication each numeral of the multiplicand can be registered in corresponding notational columns (corresponding to chains) as often as the respective numeral of the multiplier indicates. Otherwise the partial product can be obtained mentally and registered in the proper column or columns, the machine performing the required addition in that case. In division the dividend is registered according to the larger tablet-numerals and the product of the quotient figure and divisor registered complementally, and so on. This process may also be expedited by obtaining the partial products mentally. By using such chain-covers or any devices equivalent thereto tending to prevent a chain or row of keys or like operating mechanism of a calculating-machine from being used any such machine may be divided into a series of independent instruments, each performing its function individually, whose ultimate result may then be reduced and carried to the next order, as pence to shillings, shillings to pounds, ounces to pounds, pounds to bushels, bushels to chaldrons, inches to feet, feet to yards, yards to rods, rods to miles, and so on, whatever the denominations may happen to be. By hav-

ing with the chain-covers a corresponding number of shutters  $k$  the highest resultant figure of such mixed orders of numbers is hidden from view and error prevented, the cover or shutter hiding from sight the numeral under it, as shown in Fig. 1, wherein one such shutter is turned aside while the other is in use to hide the numeral under it, and with the aid of the decimal-pointer  $k^6$  moving in the slot  $k^6$  any desired number of decimals may be computed and indicated both on the chains or equivalent keys of a computing-machine and on the registering-wheels.

What I claim is—

1. The combination with a series of toothed registering-wheels carrying numbers on their peripheries, and mechanism to operatively connect the series of wheels, and chain mechanism in parallel planes tangent to said wheels, of septums, pierced for said wheel-connecting mechanism, between said wheels and chains, substantially as specified.

2. The combination with endless and yielding chains on parallel drums, of connected levers surrounded by and operating a part of the chain lying on the same side from the drum-axes, substantially as specified.

3. The combination with endless and yielding chains and connectedly-operating registering-wheels, of connected yielding levers surrounded by and carrying said chains, substantially as specified.

4. The combination with adjustable chain-carrying rollers, of endless and yielding chains and spring-actuated levers surrounded by said chains, substantially as specified.

5. The combination with endless chains, and rollers carrying them, of connected levers, within the surrounding chain, with simultaneously-acting free ends moving in opposite directions, to release and engage the chain, substantially as specified.

6. The combination with registering-wheels and endless chains tangent to said wheels, and rollers and shafts to carry said rollers and chains and a set-screw to one of said shafts, of a case slotted to admit of such adjustment of said shaft as will slacken or tighten said chain, substantially as specified.

7. The combination with connected levers, their free ends operating together and in opposite directions by the action of one of said levers, and a spring to return said levers to their normal position, of an endless chain around said levers and rollers to carry said chain, to operate, substantially as specified.

8. The combination with endless-chain mechanism in planes parallel to each other, tangent to registering-wheels actuated by said chains, of mechanism for stopping out any of said planes of mechanism, whereby, the mechanism on either side of said stop-out mechanism may register independent results, substantially as specified.

9. The combination with endless-chain mechanism in planes parallel to each other and tangent to registering-wheels actuated

by said chains, and tablets provided with numerals, arranged complementally, of mechanism for shutting out any chain, or set of chains, whereby any of said parallel planes of mechanism on opposite sides of said stop, or stops, become parts with independent functions, substantially as specified.

10 The combination with spurred and endless chains and supporting-rollers therefor, of a transverse stop to engage said spurs and a spring end with stopping mechanism, and means on one of said rollers to engage said stopping mechanism, substantially as specified.

15 11. The combination with connected levers with opposite free ends, vibrating in opposite directions, and a spring operating said levers in one direction, of an endless chain, with spurs, vibrated in its plane of motion by said levers, and toothed registering-wheels and a transverse stop to the spurs of the several chains, substantially as specified.

20 12. The combination with endless chains

and connected levers with opposed free ends, and a spring actuating said levers in one direction, and rollers for said chains, of means to adjust the distance between the axes of said rollers, substantially as specified. 25

13. The combination with toothed registering-wheels and spurred endless chains, and a transverse chain-stop, of opposite tablets parallel to and at the outer sides of said chains, each tablet provided with a double digit-scale beginning thereon at the edge of said transverse stop, substantially as specified. 30 35

14. The combination with toothed registering-wheels and endless chains with vertical, uniformly-pitched spurs, a transverse stop to engage said spurs, and opposite tablets provided with digit-scales, of an adjustable chain-cover, substantially as specified. 40

HENRY GOLDMAN.

Witnesses:

WM. ZIMMERMAN,  
P. H. HOLLAND.